



DEVELOPMENT OF DESIGN SKILLS OF HIGH SCHOOL STUDENTS

¹Aminov Akmal Shavkatovich, ²Xodjayeva Nodira Sharifovna
Teacher, Bukhara State University¹, Tashkent State Transport University, senior lecturer²
akmaljon84ts@mail.ru¹

ANNOTATION

The article deals with the development of design skills of secondary school students.

Key words: project, imagination, creativity, vivid image

INTRODUCTION

The main requirement today is to train qualified personnel. While the personnel we train are diligent, demanding, inquisitive, and innovative, we must move quickly into the future. To do this, today's youth must be creative. These skills and competencies should be acquired by students in general secondary schools. Unlike other subjects in general secondary schools, "Drawing" classes have a great opportunity to develop students' imagination and creative abilities. This is due to the fact that in drawing classes, theoretical training is closely linked with practical training. This allows students to work independently and demonstrate their abilities to the best of their ability. During the lesson, students will be happy to see the project they have created, compare it with the work of their classmates, be proud of their achievements, and correct any shortcomings. This is the first step in helping students develop as independent individuals. The role of the teacher in the development of such skills is also significant. The teacher must first have the skills to create such projects. Ability, on the other hand, emerges through relentless research and hard work. In high school, students study the humanities and aesthetics. In order to attract them to the aesthetic sciences, it is necessary to develop the ability to create models and inventions of various drawings, to put their products on display and encourage them in school exhibitions.

MAIN PART

In high school, in the subject of "Drawing", drawing and modeling of complex jars, which are complex to produce students' ingenuity and creativity, by performing complex drawings and vivid descriptions and models of details consisting of simple objects, one of the two details. to work on such topics as completing the design of an additional detail and preparing its clarity in order to connect to one another. It is possible to create very complex drawings with students, as well as develop their imagination. A science teacher, with a good knowledge of his profession, can make school drawing interesting, develop inventive skills and interest in science. Requires a creative approach to students in the performance of these tasks, develops his imagination, develops an interest in the science of drawing. Let's look at 5 types of product design in the development of imagination and skills.

1. One of the imaginative lessons in the subject of drawing is to design an additional detail for turning the shaft to the left and right. The design of the shaft is shown by drawing a drawing with the reverse lugs inserted into it, a cylindrical pin inserted into it, fastened on both sides with a spring, the project is clearly separated and combined with one axis (Fig. 1).

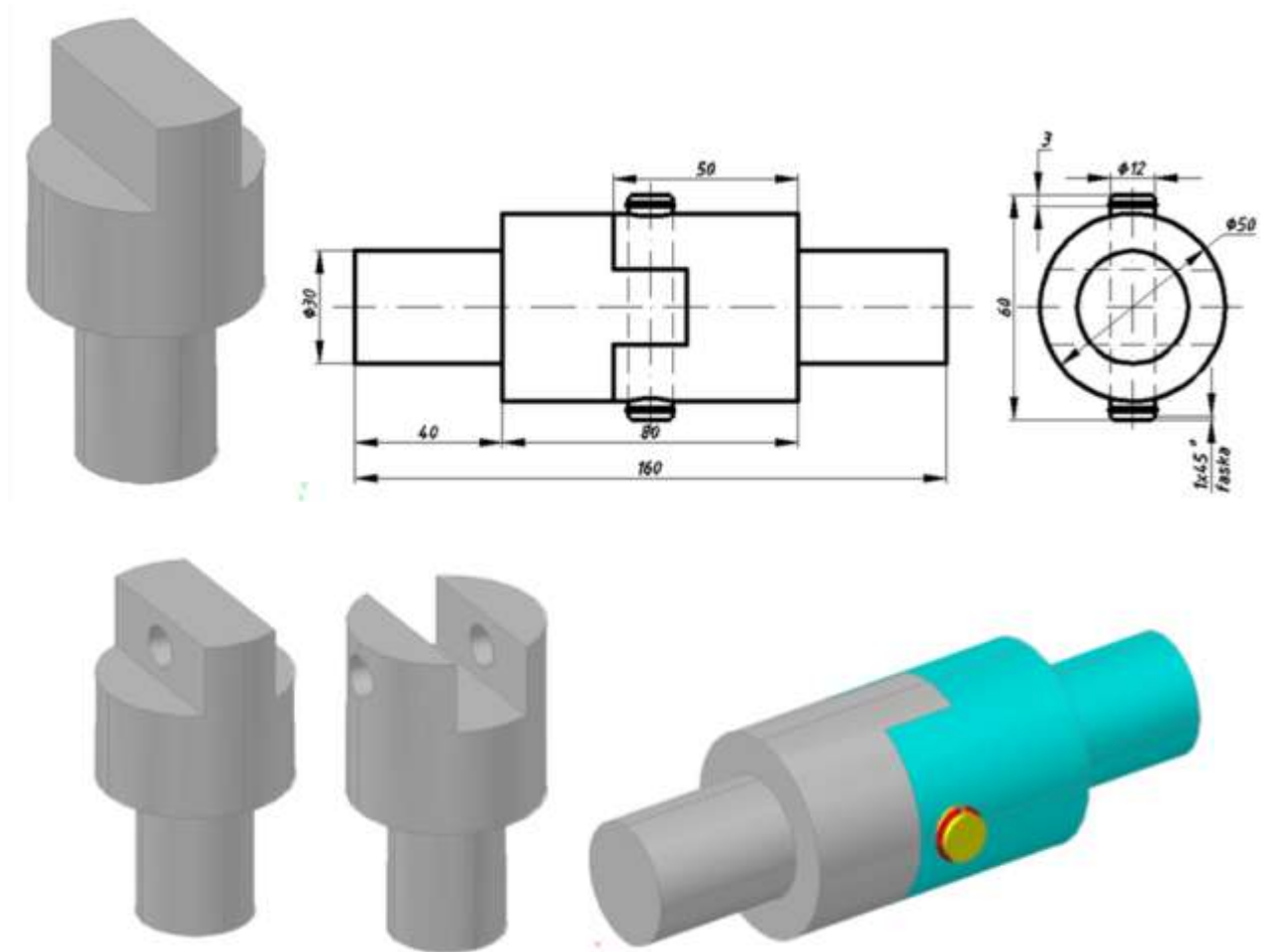

Figure 1

In this case, students imagine and design the figurative detail needed for the shaft. It is also possible to design the issue in a different figure. It depends on the imagination of students.

2. Design a diagram of the connected sun with the help of a compass (Figure 2). At the heart of the bowls, candlesticks, jugs and sunbeds used in life are various circular curves and connections. Such dishes are widely used, despite their versatility. When mastering the topic of the lesson, students are given a color picture of the sun and carry out the project based on the rules of its connection. After drawing the junction, it is explained how to set the required dimensions.

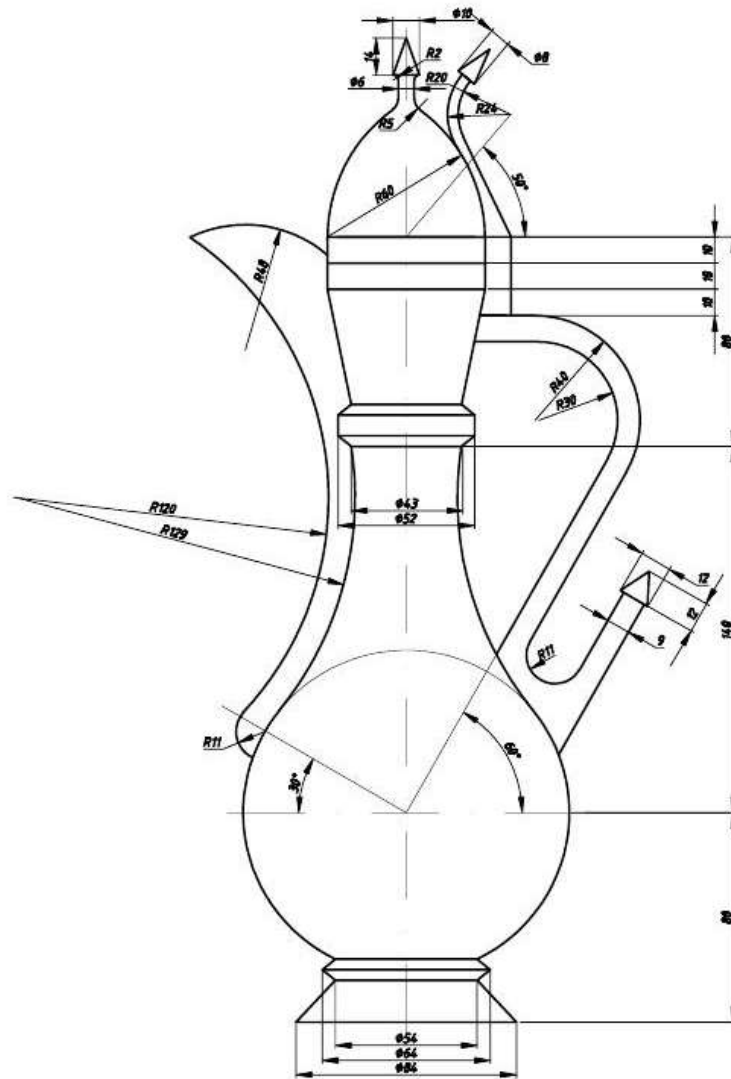

Figure 2

3. A complex detail drawing consisting of different objects and a clear image project (Figure 3). When mastering the projection section of the science of drawing, it is first necessary to know the projections of different geometric objects and their apparent and the intersection of objects. In this drawing, a complex detail projection formed as a result of the intersection of different objects and a detail cut based on three projections are made by making the necessary cuts to it.

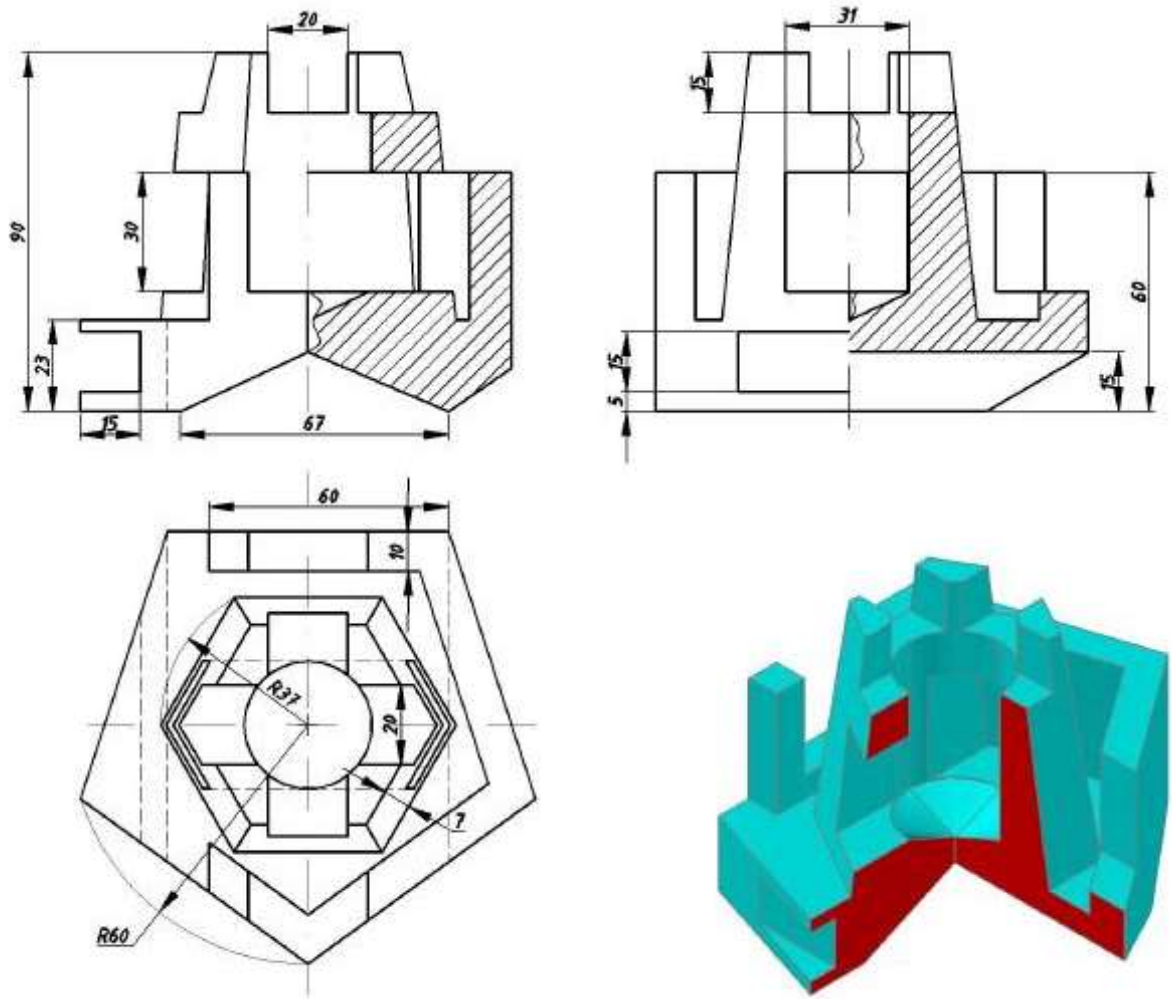

Figure 3

4. Design a simple detail cut from soap material (Figure 4). Any simple detail of the prismatic material is marked with a ruler and a pencil (Figure 4 a). The detail model is performed by cutting the marked area with a special knife (Fig. 4 b). It is also possible to make a model of the soap based on the two projections given in the material.

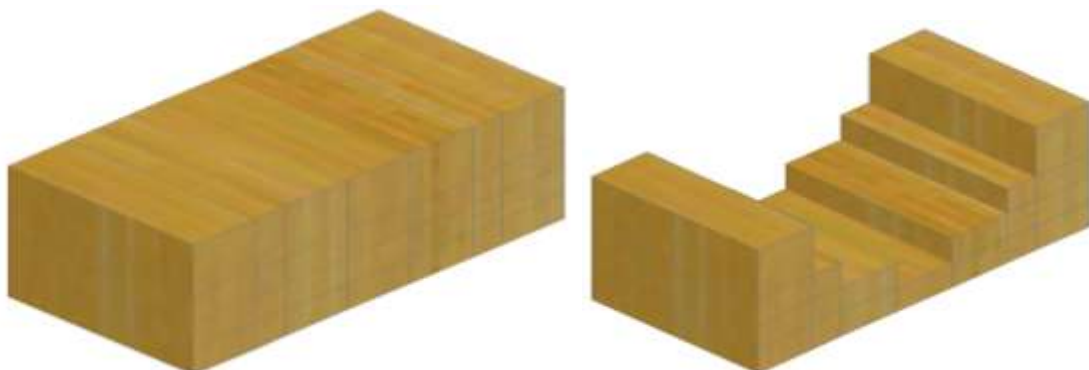

Figure 4

5. Preparation of a detailed model of a paper material (Figure 5). After the students have mastered the projection drawings, the teacher gives concepts to create a model of a simple detail. The distribution of the student detail model is projected by drawing on paper (Figure 5, a). Excess space is left to glue each other to the spread of the detail model. After cutting the spread of the detail model, they are glued (Fig. 5, b).

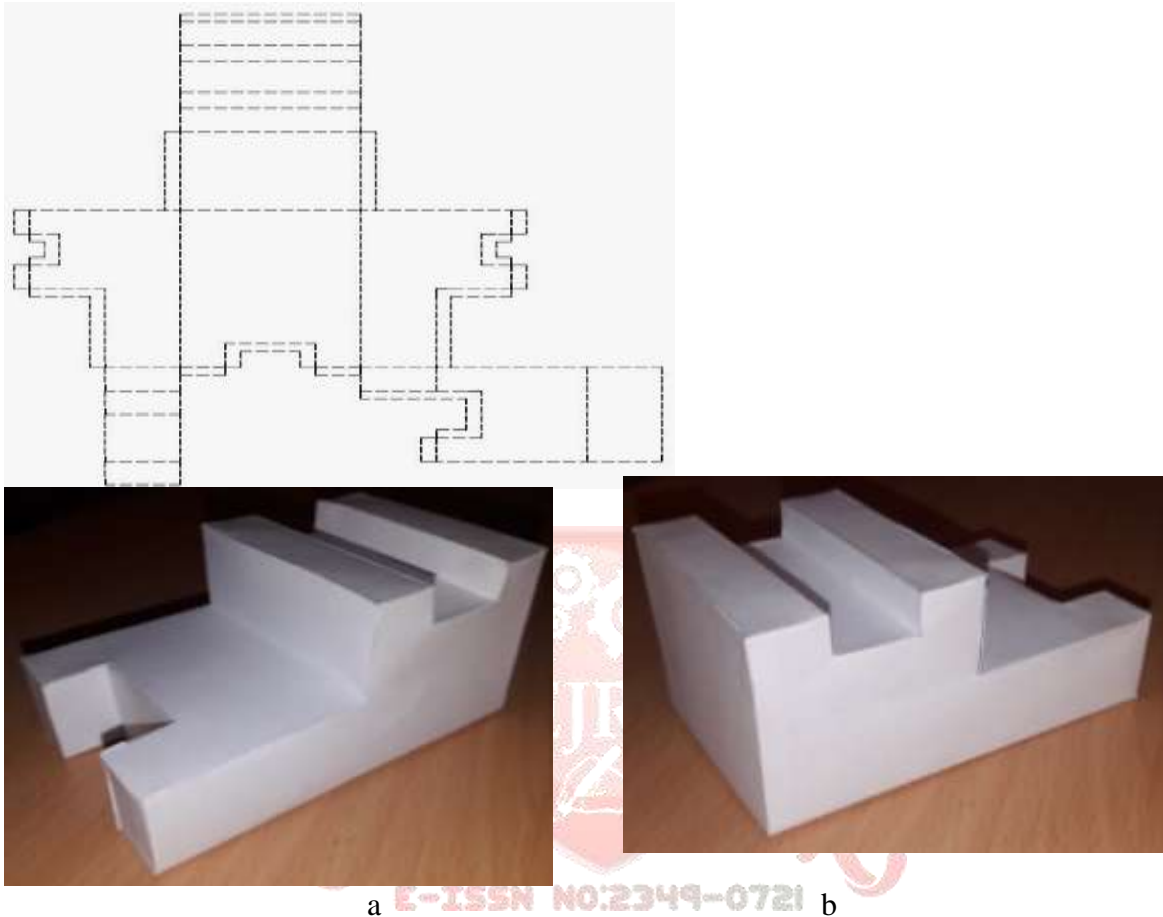

Figure 5

In conclusion, students will learn the secrets of the science of drawing, increasing their imagination in the drawing lessons to perform tasks on the design of details. Creates all-round creativity in designing details. When such design lessons are conducted, students are explored, their design skills are developed, and their interest in science increases. He also studies the projection and model of the detail and their standard drawings.

REFERENCES

1. Rahmonov I.T. Didactic games on drawing. - T., 1992
2. Raxmonov I.T. Draw and read drawings. - T., "Andy". 1992.
3. Botvinnikov AD, Vinogradov VN, Vishnepolsky IS, Textbook for 7-8 grades of secondary schools "Drawing"). - T., 1994
4. Umronkhojayev A. "Drawing" - T., "Teacher". 2006.
5. Yodgorov J. Sobirov T.R. "Geometric and projection drawing" T. 2008.